

SERIES 47



Low Cost Sealed Pushbutton Switch

The Series 47 is a uniquely designed sealed miniature pushbutton switch. The silicone button and body can be panel mounted and terminated with a standard connector or mounted in a P.C. board. The switches come in two levels of sealing: a panel sealed only version and a fully sealed version with epoxy sealed base. Both meet respective IP67 requirements. The buttons are available in seven different colors. All this at a very affordable price.

KEY FEATURES:

- Sealed to IP67
- Small size
- 7 button colors
- P.C. terminals (connector available)
- Long life
- Low cost

APPLICATIONS

- Marine equipment
- Medical equipment
- Outdoor controls
- Food processing equipment
- Appliances
- Recreational vehicles

ORDERING INFORMATION:

Part Number	Button Color	Panel Sealed	Epxoy Sealed Base
47-1111	Black	✓	✓
47-1121	Red	✓	✓
47-1131	Green	✓	✓
47-1141	White	✓	✓
47-1151	Yellow	✓	✓
47-1161	Blue	✓	✓
47-1171	Orange	✓	✓
47-2111	Black	✓	
47-2121	Red	✓	
47-2131	Green	✓	
47-2141	White	✓	
47-2151	Yellow	✓	
47-2161	Blue	✓	
47-2171	Orange	✓	

STANDARDS / AGENCY / RATINGS:



SERIES 47—LOW COST SEALED PUSHBUTTON

47-11X AND 47-21X

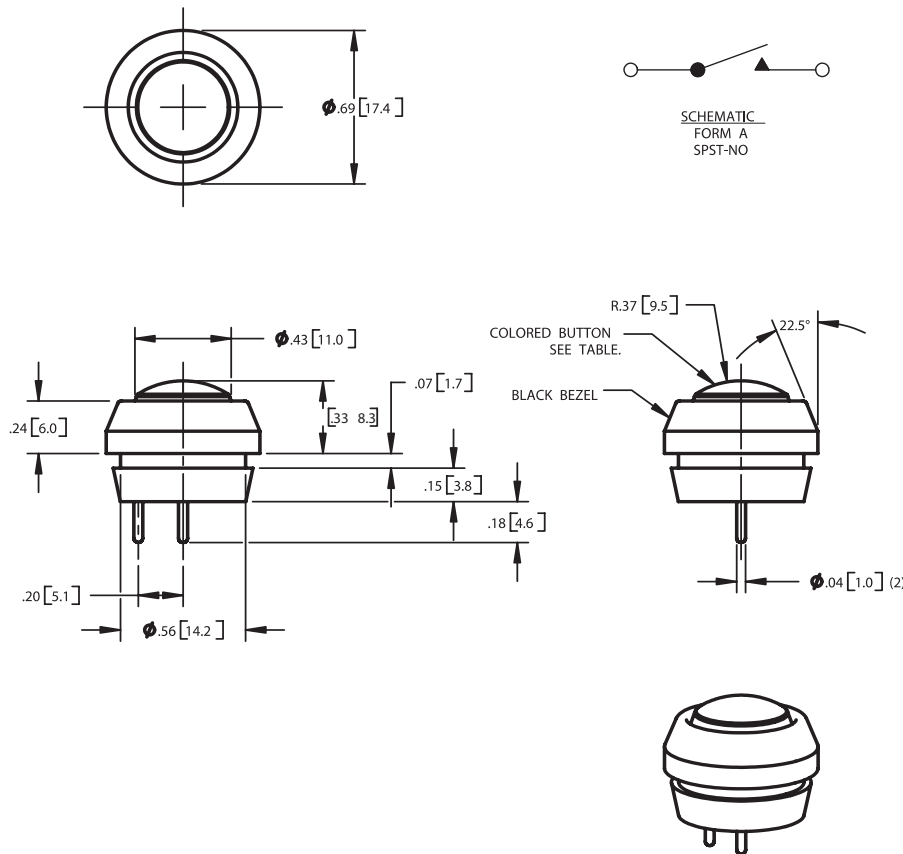

SCHMATIC
FORM A
SPST-NO

MECHANICAL / ELECTRICAL CHARACTERISTICS:

Travel (nom):

.020

Life (min):

100,000 cycles

Operating force (nom):

1,000g

Sealed to:

IP67

Operating temperature:

-40°C to +85°C

Button material:

silicone

Contact:

metal snap dome providing a tactile feel

Terminal finish:

gold over nickel

Dielectric strength:

1,000 VRMS

Insulation Resistance:

10,000 Megohms

Contact Resistance (initial):

<100 Ohms

Current rating:

20 mA @ 28 VDC

Switch terminals mate with

ITW Pancon Mas-Con Connector CE100F24-3-DB

Recommended panel cut-out:

.565/.560 dia (Ø14.40/14.22)

Recommended panel thickness:

.060 (1.52) max

ITW Switches

7301 W. Ainslie Street
Harwood Heights, IL 60706

800.544.3354

708.667.3370

708.667.3440 (Fax)

www.itwswitches.com

customer_service@itwswitches.com