

**KILOVAC LEV200 Series Contactor With 1 Form X
Contacts Rated 500+ Amps, 12-900Vdc**

Product Facts

- Designed to be the lowest cost sealed contactor in the industry with its current rating (500+A carry, 2000A interrupt at 320Vdc)
- Available with bottom or side mounting — not position sensitive
- Optional auxiliary contact for easy monitoring of power contact position
- Hermetically sealed — intrinsically safe, operates in explosive/harsh environments with no oxidation or contamination of coils or contacts, including long periods of non-operation
- Typical applications include battery switching and backup, DC voltage power control, circuit protection and safety
- Versatile coil/power connections
- Designed and built in accordance to AIAG QS9000



Coil Data (Valid Over Temperature Range) ⁴

Nominal Voltage	12Vdc	24Vdc	48Vdc
Pickup Voltage (Will Operate)	9.0Vdc	19.0Vdc	38.0Vdc
Voltage (Max.)	15Vdc	30Vdc	60Vdc
Dropout Voltage	0.75 - 2.0Vdc	1.0 - 5.0Vdc	2.0 - 7.0Vdc
Coil Resistance @ 25° (Typ.)	11 ohms	40 ohms	145 ohms

Ordering Information

Typical Part Number ►

LEV200 A 4 N A A

Series:

LEV200 = 500+ Amp, 12-900Vdc Contactor

Contact Form:

A = Normally Open
H = Normally Open with Aux. Contacts. (Option "H" requires option "A" in Coil Wire Length and option "N" in Coil Terminal Connector.)

Note: Other auxiliary contact forms available. Consult factory.

Coil Voltage:

4 = 12Vdc 5 = 24Vdc B = 28Vdc
6 = 48Vdc 7 = 72Vdc
8 = 96Vdc L = 110Vdc O = 115Vac 9 = 240Vac

Notes: Consult factory for detailed specifications and availability of coils not listed in "Coil Data" table above. In coil voltage codes, 115Vac is designated by the letter "O" rather than the numeral "0."

Coil Wire Length:

A = 15.3 in (390 mm) N = None (Requires option "A" in next step.)

Coil Terminal Connector:

N = None, stripped wires (Requires option "A" in previous step.)
A = Studs, #10-32 Threaded (Electrical connection is made to the tab at the base of the stud.)
Note: Specify option A, stripped wires, for coil voltages > 96Vdc

Mounting & Power Terminals:

A = Bottom Mount & Male 10mm x M8 Threaded Terminals
F = Side Mount & Male 10mm x M8 Threaded Terminals

Consult factory regarding other available mountings and power terminals.

Performance Data

Contact Arrangement, Power Contacts — 1 Form X (SPST-NO-DM)

Rated Operating Voltage — 12 - 900 VDC

Continuous (Carry) Current, Typical — 500 A @ 65°C, 400 mcm conductors

Consult Tyco Electronics for required conductors for higher (500+ A) currents

Make/Break Current at Various Voltages ¹ — See graph next page

Break Current at 320VDC ¹ — 2,000 A, 1 cycle ³

Contact Resistance, Typ. (@200A) — 0.2 mohms

Load Life — See graph next page

Mechanical Life — 100,000 cycles

Contact Arrangement, Auxiliary Contacts — 1 Form A (SPST-NO)

Aux. Contact Current, Max. — 2A @ 30VDC / 3A @ 125VAC

Aux. Contact Current, Min. — 100mA @ 8V

Aux. Contact Resistance, Max. — 0.417 ohms @ 30VDC / .150 ohms @ 125VAC

Operate Time @ 25°C

Close (includes bounce), Typ. — 25 ms
Bounce (after close only), Max. — 7 ms
Release (includes arcing), Max @ 2000A — 12 ms

Dielectric Withstanding Voltage — 2,200 Vrms @ sea level (leakage <1mA)

Insulation Resistance @ 500VDC — 100 megohms ²

Shock, 11ms 1/2 Sine, Peak, Operating — 20 G

Vibration, Sine, 80-2000Hz., Peak — 20 G

Operating Ambient Temperature — -40°C to +85°C

Weight, Typical — 1.3 lb. (.60 kg)

Notes:

- ¹ Main power contacts
- ² 50 at end of life
- ³ Does not meet dielectric & IR after test, 1700 amp for unit with Aux. Contacts
- ⁴ Contacts will operate with 0.8V_{nom} < V_{coil} < 1.1V_{nom} over temperature range.

Invalid Combinations/Reason

- LEV200H-NA_ No auxiliary function with coil studs
- LEV200_ONA_ No coil studs with rectifier circuit
- LEV200_9NA_ No coil studs with rectifier circuit
- LEV200_O_F No side mont with rectifier circuit
- LEV200_9_F No side mount with rectifier circuit

For factory-direct application assistance, dial 800-253-4560, ext. 2055, or 805-220-2055.

KILOVAC LEV200 Series (Continued)

Outline Dimensions

Side Mount Enclosure

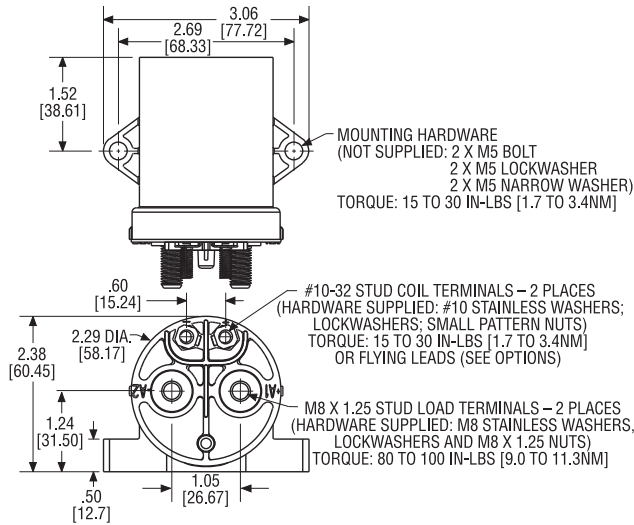

Note: When stud terminals are specified for coil connections, the electrical connection is made at the tab located at the base of the stud.

Bottom Mount Enclosure

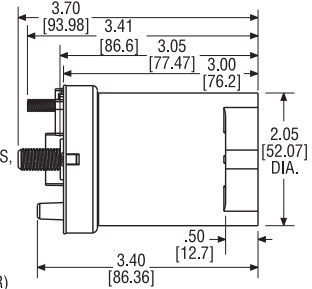
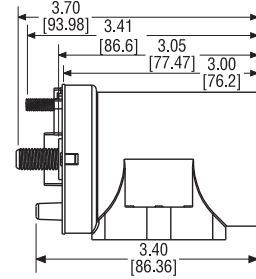
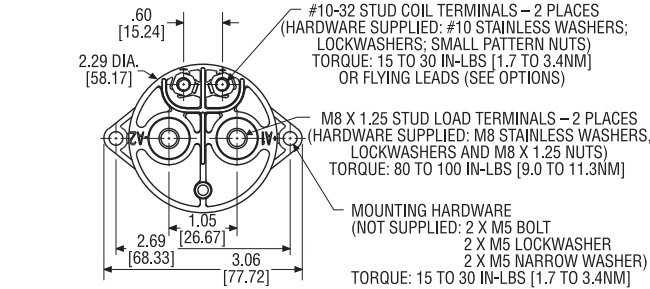

Estimated Make & Break Power Switching Ratings

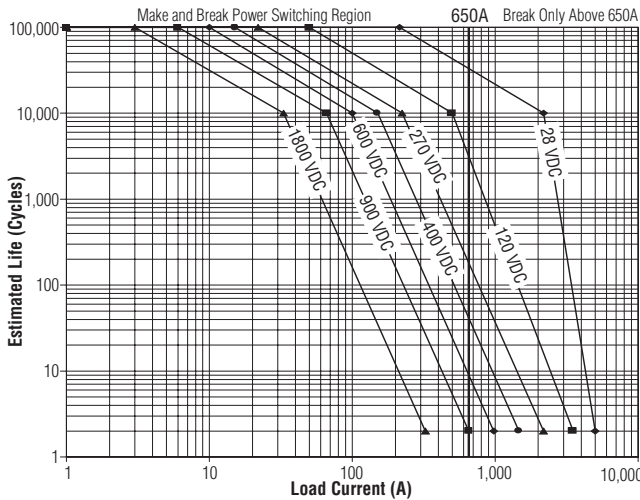

- NOTES:**
- 1) For resistive loads with 300H maximum inductance. Consult factory for inductive loads.
 - 2) Estimates based on extrapolated data. User is encouraged to confirm performance in application.
 - 3) End of life when dielectric strength between terminals falls below 50 megohms @ 500VDC.
 - 4) The maximum make current is 650A to avoid contact welding.

Electrical Load Life Ratings for Typical LEV Applications

Make/Break Life Capacitive & Resistive Loads at 320VDC (1) (2)		
@90% capacitive pre-charge (make only) see chart below	Cycles	50,000
@80% capacitive pre-charge (make only) see chart below	Cycles	50
2,000A (break only) (1)	Cycles	1*
Mechanical Life	Cycles	100,000

- (1) Resistive load includes inductance L = 25μH. Load @ 2500A tested @ 200μH.
 (2) Life based on projected Weibull Life with 95% reliability.
 * Does not meet dielectric and IR after test.

LEV200 Capacitive Make Test Curves for Pre-Charged Motor Controller

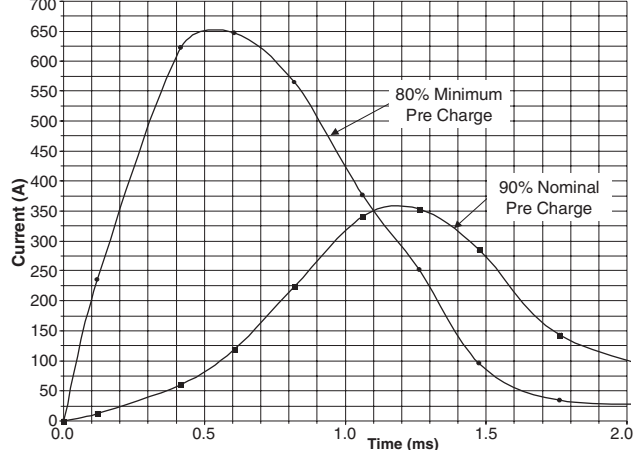

For factory-direct application assistance, dial 800-253-4560, ext. 2055, or 805-220-2055.